

User manual  
**Hoof trimming crush**  
**SA0049**



**Manufacturer:**

Loon- en Mechanisatiebedrijf Wopa-Lichtenvoorde B.V.  
Rector Hulshofstraat 10  
7135 JV Harreveld  
The Netherlands

: +31-(0)544 372415  
: +31-(0)544 372445  
Email: info@wopa.com  
Website: www.wopa.com

© Copyright 2015

No part of this publication may be reproduced, stored in a search system or transferred in any form whatsoever, either electronically or mechanically, or by photocopying or recording, or in any other way whatsoever without prior written consent from Loon- en Mechanisatiebedrijf Wopa-Lichtenvoorde B.V. (hereinafter in this manual also referred to as "Wopa").

## Introduction

Loon- en Mechanisatiebedrijf Wopa-Lichtenvoorde B.V. specialises in development and manufacture of hoof trimming and treatment crushes for cows and bulls for professional users as well as for cattle farmers.

Our crushes are developed and manufactured in the highest possible quality, according to the strictest requirements as far as safety, user convenience, animal welfare and hygiene are concerned, always striving for an optimum.

This manual contains information and instructions relevant to installation, operation and maintenance of the machine.



- The machine is not suitable for use in explosive hazardous environments.
- All persons responsible for operation must, at minimum, read and comprehend the sections on operation and safety of these operating instructions.
- All persons responsible for assembly, installation, maintenance and/or repair must read and comprehend all these operating instructions.
- The user is responsible for interpretation and use of this manual under all conditions. Should you have any doubts or questions regarding the correct interpretation, please contact the owner or the supervisor.
- Keep this manual nearby the installation and within the users' reach.
- Keep a log of all major maintenance work, adaptations to the installations and observations, see Annex 8.1.
- Changes to the installation/machine are not permitted without prior written approval from the supplier.
- Contact the supplier for any special maintenance work not included in this manual.
- Comply with the safety requirements as given in Section 3 at all times.
- Proper functioning as well as the safety of the system can only be guaranteed if the recommended maintenance is carried out correctly and on time.

## Warranty

The warranty is subject to the following limitations. The warranty period for products supplied by Wopa is 12 months from the date on the purchasing document. The warranty is limited to production and material errors and therefore does not cover any breakdowns due to a part of the product exposed to any type of wear. Normal wear as can be expected from using this product is therefore excluded.

1. Wopa's responsibility remains limited to replacing defective parts; we recognise no claims to any other type of loss or costs.
2. The warranty is automatically void in case of overdue or poorly implemented maintenance.
3. Should you have any doubts regarding maintenance work or should the machine fail to operate correctly, contact the supplier.
4. The warranty does not apply if the defect is the result of incorrect or negligent use or of maintenance carried out contrary to the instructions in this manual.
5. The warranty is void if any repairs or adaptations are made to the product by third parties.
6. Defects ensuing from damage or accidents caused by external factors are excluded from the warranty.
7. If we replace any parts in accordance with the obligations ensuing from this warranty, the parts we replaced become our property.

## Table of Contents

<b>INTRODUCTION .....</b>	<b>3</b>
<b>WARRANTY .....</b>	<b>4</b>
<b>TABLE OF CONTENTS .....</b>	<b>5</b>
<b>EC CONFORMITY DECLARATION (COPY) .....</b>	<b>6</b>
<b>OVERVIEW OF SYMBOLS.....</b>	<b>7</b>
<b>PICTOGRAMS .....</b>	<b>8</b>
<b>1. TECHNICAL INFORMATION.....</b>	<b>10</b>
<b>2. DESCRIPTION OF THE INSTALLATION.....</b>	<b>11</b>
2.1. DESCRIPTION OF THE MAIN COMPONENTS SA0049 .....	11
2.2. ELECTRICAL INSTALLATION .....	14
2.3. HYDRAULIC INSTALLATION .....	15
<b>3. SAFETY .....</b>	<b>16</b>
3.1. GENERAL.....	16
3.2. DURING NORMAL USE .....	17
3.3. OPERATING PERSONNEL.....	17
<b>4. INSTALLATION .....</b>	<b>18</b>
4.1. LOCATION.....	18
4.2. CONNECT THE MACHINE. ....	20
4.3. PREPARING FOR TRANSPORTATION.....	20
<b>5. OPERATION .....</b>	<b>21</b>
5.1. STARTING UP .....	21
5.2. EMERGENCY STOP. ....	21
5.3. PRODUCTION .....	22
5.4. HOOK UP THE FRONT LEG. ....	23
<b>6. MAINTENANCE .....</b>	<b>24</b>
6.1. MAINTENANCE DIAGRAM .....	24
6.2. CLEAN THE MACHINE. ....	26
6.3. LUBRICATION OF REAR GATE.....	26
6.4. CHECK OIL LEVEL/REPLACE OIL.....	27
6.5. CHECK PLAY IN THE WHEELS.....	28
6.6. CHECK THE SHAFT BOLTS. ....	28
6.7. PARTS.....	28
<b>7. DISPOSAL AS WASTE .....</b>	<b>29</b>
<b>8. APPENDIX .....</b>	<b>30</b>
8.1. LOGBOOK .....	30
<b>LIJST MET AFBEELDINGEN</b>	
FIGURE 1 OVERVIEW SA0049 .....	12
FIGURE 2 OVERVIEW OF THE HYDRAULIC INSTALLATION .....	15
FIGURE 3 DETAILS OF CONVERSION FROM TRANSPORT SET-UP TO WORKING SET-UP (SA0049) .....	18
FIGURE 4: DETAIL OF HOOKING UP FRONT LEG .....	23
FIGURE 5: LUBRICATION OF REAR GATE .....	26
FIGURE 6: HYDRAULIC FLUIDS TO BE USED.....	27
FIGURE 7: DETAILS OF SHAFT BOLT TORQUE SETTINGS .....	28

## EC conformity declaration (copy)

We, Loon- en Mechanisatiebedrijf Wopa-Lichtenvoorde B.V.  
Rector Hulshofstraat 10  
7135 JV Harreveld  
The Netherlands

☎: +31-(0)544 372415  
✉: +31-(0)544 372445  
Email: info@wopa.com  
Website: www.wopa.com

declare, entirely under our own responsibility, that the product:

**machine :** Hoof trimmingcrush  
**type:** SA0049

to which this declaration pertains, is consistent with the stipulations in Directives:

2006/42/EC (Machine Directive)  
2004/108/EC (EMC Directive)

the following standards were taken into account:

<b>NEN-EN-ISO 12100</b>	Safety of machinery. Basic definitions, general design principles.
<b>NEN-EN 349</b>	Safety of machinery – Minimum gaps to avoid crushing of parts of the human body.
<b>NEN-EN ISO 13849-1</b>	Safety of machinery – Parts of the control systems with a safety function – Section 1: General design principles
<b>NEN-EN 4413</b>	Hydraulics – General rules and safety requirements for systems and their components
<b>NEN-EN 60204-1</b>	Safety of machinery – Electrical equipment of machines Section 1: General requirements

*The undersigned is authorised to compile the Technical Dossier:*





The Netherlands - Harreveld, December 2015

J.W.A. Wopereis  
Managing Director











## Overview of symbols

The following symbols are used for all actions that jeopardise the safety of the user and/or technician and require caution.



	Attention!
	Hazard: High voltage!
	Hazard: High temperature!
	Tip: Offers quick insight or tips to carry out certain actions more easily and simply.

## Pictograms

A number of pictograms and alerts are affixed to the installation to indicate possible risks to users, among other things.

Pictogram	Description	Location
	<ul style="list-style-type: none"> <li>Type plate</li> </ul>	<ul style="list-style-type: none"> <li>On the machine frame</li> </ul>
	<ul style="list-style-type: none"> <li>Read the user manual</li> <li>Wear safety goggles when operating machine</li> <li>Wear hearing protection when operating machine.</li> </ul>	<ul style="list-style-type: none"> <li>On the machine frame</li> </ul>
	<ul style="list-style-type: none"> <li>The presence of unauthorised persons within turning range of the box is strictly prohibited.</li> </ul>	
	<ul style="list-style-type: none"> <li>Warning pictograms System under pressure.</li> </ul>	<ul style="list-style-type: none"> <li>On either side of the frame</li> </ul>
	<ul style="list-style-type: none"> <li>Warning pictograms for mechanical and electrical hazards</li> </ul>	<ul style="list-style-type: none"> <li>On the machine frame</li> </ul>
	<ul style="list-style-type: none"> <li>Warning pictogram Snagging hazard for hand</li> </ul>	<ul style="list-style-type: none"> <li>On the machine frame</li> </ul>
	<ul style="list-style-type: none"> <li>Warning pictogram Never walk under the load during hoisting.</li> </ul>	<ul style="list-style-type: none"> <li>On the machine frame</li> </ul>
	<ul style="list-style-type: none"> <li>Crushing hazard</li> </ul>	<ul style="list-style-type: none"> <li>By the rear gate, if present.</li> </ul>



	<ul style="list-style-type: none"> <li>Warning pictogram Electrical hazards.</li> </ul>	<ul style="list-style-type: none"> <li>On the machine frame</li> </ul>
	<ul style="list-style-type: none"> <li>Warning pictogram Snagging hazard for foot.</li> </ul>	<ul style="list-style-type: none"> <li>On the machine frame</li> </ul>
	<p style="text-align: center;"><b>ATTENTION!</b></p> <ul style="list-style-type: none"> <li>Check regularly whether the pictograms and signs are still clearly recognisable and legible. Replace if this is no longer the case.</li> </ul>	

## 1. Technical information

	SA0049	
<b>General</b>		
Ambient temperature during operation	- 10 to 40	°C
Noise production	< 75	dB(A)
<b>Machine dimensions</b>		
Length	2100	mm
Width	1750	mm
Height	2000	mm
Weight	475	kg
<b>Maximum product dimensions</b>		
Length	3290	mm
Width	1750	mm
Height	2400	mm
Weight	750	kg
<b>Electrical connection</b>		
	Standard / option	
Power supply	1 phase / 3 phase	-
National voltage	230/400	V
Required fuse	8.7/5.9	A
Connected value	1.5/2.5	kVA
<b>Hydraulic installation?</b>		
Maximum operating pressure	120	bar
Tank volume	5.5	litre
Type of oil	See Figure 7	
<b>Data for road transport</b>		
Axial load	750	kg
Maximum drawbar load	100	kg
Coupling	ISO 55 mm	-
Connection plug	7 or 13	pole

\* see electrical diagram

\* If the box is fitted with a 230V plug, the plug must be connected to a wall-mounted socket protected by a residual current operated circuit-breaker (always according to the local regulation in effect). (30mA)

## 2. Description of the installation

	<p style="text-align: center;"><b>FUNCTION</b></p> <ul style="list-style-type: none"><li>• This section gives an overview of the most important components and functions. If detailed information is available elsewhere in the manual, you are referred to the specific sections.</li><li>• The design of your crush may differ from the figures below.</li></ul>
---	--

### 2.1. Description of the main components SA0049

	<p style="text-align: center;"><b>FUNCTION</b></p> <ul style="list-style-type: none"><li>• The SA0049 was developed especially for dairy cattle and beef cattle hoof trimming.</li><li>• Version SA0049 is equipped with an axle with a draw bar and is suitable for transport on public roads.</li></ul>
---	---

The main components of the crush are shown in the illustration below:

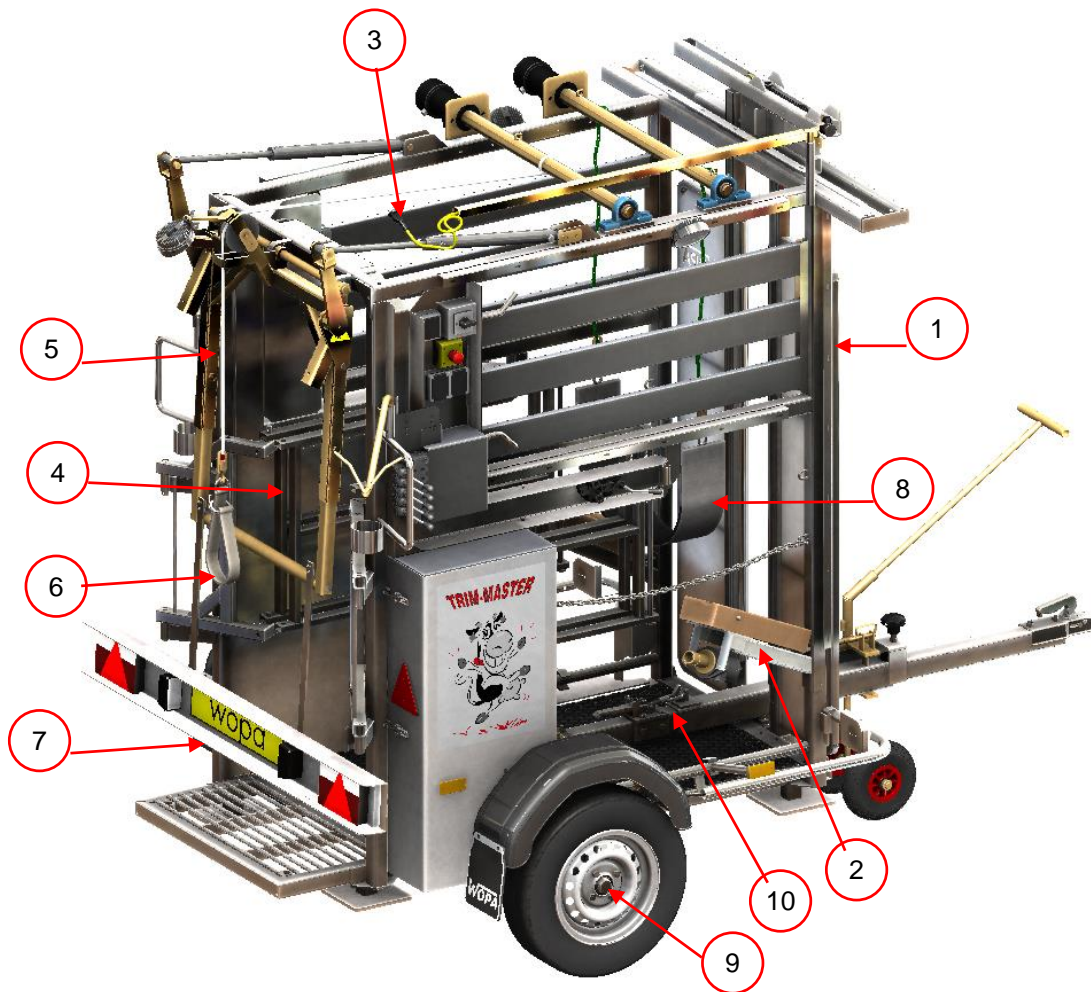



Figure 1 Overview SA0049

	Component	Description	See Section
1	Front gate	<ul style="list-style-type: none"> <li>The front gate can be set to 3 positions with the hydraulic controls:</li> <li>Entirely open: the cow can exit the crush at the front.</li> <li>Partially open: the cow can move its head through the front gate but not its shoulders. Stationary position.</li> <li>Closed: the front gate is closed behind the animal's head.</li> </ul>	-
2	Front leg support	<ul style="list-style-type: none"> <li>The cow's front leg can be secured to the front leg support by means of a hydraulic winch so the leg can be treated.</li> </ul>	5.4

	Component	Description	See Section
3	Electrical connection cable	<ul style="list-style-type: none"> <li>The crush must be connected to the electricity network for power supply for operation and the hydraulic power unit.</li> </ul>	
4	Folding gate	<ul style="list-style-type: none"> <li>The standard version includes a folding gate for guiding the cattle.</li> </ul>	
5	Hydraulic rear gate	<ul style="list-style-type: none"> <li>Once the cow is moved into the crush, the rear gate is placed lightly against the back of the animal.</li> </ul>	
6	Hind leg (hydraulic)	<ul style="list-style-type: none"> <li>After the belt is attached round the hind leg, the leg can be lifted with the hydraulic winch so the hoof can be treated.</li> </ul>	
7	Transport set (light bar) (SA0049)	<ul style="list-style-type: none"> <li>A light bar with a license plate is attached to the crush for transport on public roads.</li> </ul>	
8	Belly strap (hydraulic)	<ul style="list-style-type: none"> <li>Once the cow is moved into the crush, the belly strap is lifted hydraulically behind the front legs.</li> </ul>	
9	Transport set (axle) (SA0049)	<ul style="list-style-type: none"> <li>An axle with mudguards is attached to the crush for transport on public roads.</li> </ul>	
10	Transport set (draw bar arm) (SA0049)	<ul style="list-style-type: none"> <li>A draw bar arm is attached to the crush for transport on public roads</li> </ul>	

## 2.2. Electrical installation

	<p><b>FUNCTION</b></p> <ul style="list-style-type: none"> <li>• The electrical installation supplies the power for the hydraulic power unit, lighting and sockets.</li> <li>• See the electrical diagram in the control panel of every crush for the rest of the structure and controls of the electrical installation included in the delivery.</li> <li>• The placement of the control components on your installation may differ from the photo below.</li> </ul>
---	--

	<p><b>ATTENTION!</b></p> <ul style="list-style-type: none"> <li>• Work on the electrical installation can only be carried out by a technical expert.</li> </ul>
---	---

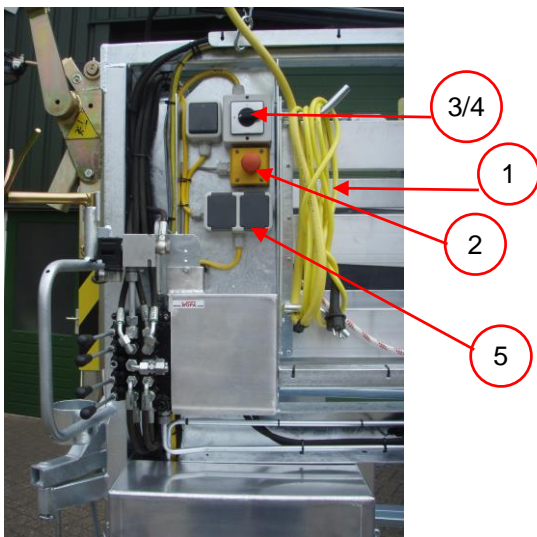

The installation consists of the following components

	Component	Description	Section / location
1	Power supply cable	<ul style="list-style-type: none"> <li>• To connect the machine to the power supply.</li> </ul>	
2	Emergency stop	<ul style="list-style-type: none"> <li>• The emergency stop switches off all operations.</li> </ul>	
3	Power unit start/stop button	<ul style="list-style-type: none"> <li>• Pushing the button switches the power unit on or off.</li> </ul>	
4	Three-phase current switch	<ul style="list-style-type: none"> <li>• This switch is only present if the controls are suitable for 3-phase current (option).</li> <li>• The switch must be set to position 1 or 2, depending on the direction of rotation of the power network one wants to connect to. The hydraulic power unit can only pump oil in 1 of these positions. If no oil is being pumped, the switch must be flipped immediately to prevent damage to the installation.</li> </ul>	
5	Sockets	<ul style="list-style-type: none"> <li>• The grinders can be connected to these.</li> </ul>	

### 2.3. Hydraulic installation

	<p><b>FUNCTION</b></p> <ul style="list-style-type: none"> <li>• The various functions are driven by means of the hydraulic installation</li> <li>• See the hydraulic diagram for a detailed description of the installation.</li> <li>• The placement of the control components on your installation may differ from the photo below.</li> </ul>
---	--

	<p><b>ATTENTION!</b></p> <ul style="list-style-type: none"> <li>• Work on the hydraulic installation can only be carried out by a technical expert.</li> </ul>
---	--

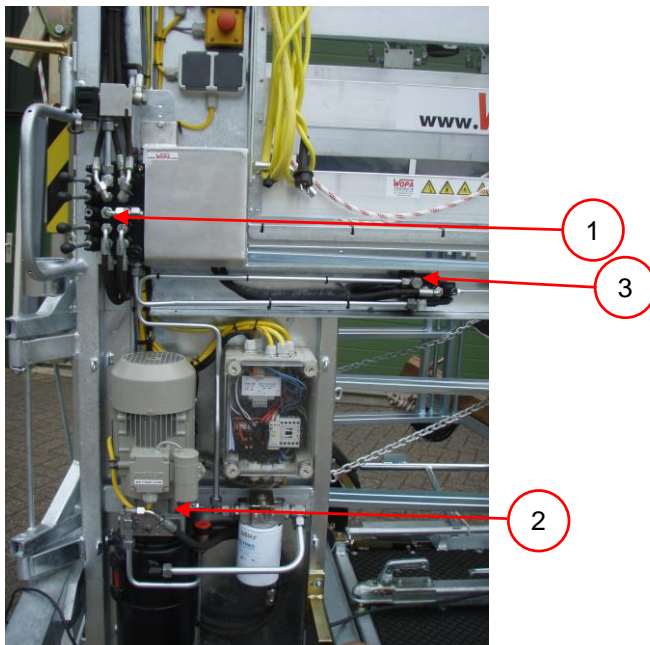



Figure 2 overview of the hydraulic installation

Figure 2	Component	Description	Section / location
1	Valve block in general	<ul style="list-style-type: none"> <li>• The valves control the following functions: <ul style="list-style-type: none"> <li>• Hind legs</li> <li>• Front gate</li> <li>• Hydraulic shaft</li> <li>• Belly strap</li> <li>• Rear gate</li> </ul> </li> </ul>	
2	Power unit	<ul style="list-style-type: none"> <li>• See the type plate on the motor to connect the machine to the power supply.</li> </ul>	
3	Front leg valve	<ul style="list-style-type: none"> <li>• It operates the front leg winch.</li> <li>• As an option, the crush can be equipped with a hydro-motor on each side.</li> </ul>	

## 3. Safety

### 3.1. General

	<ul style="list-style-type: none"><li>• The guarantee will lapse and no liability will be accepted in the event of damage caused by repairs and/or modifications not authorised by the supplier.</li><li>• In the event of faults please contact the supplier.</li><li>• The working area around the installation must be safe. The owner of the installation must take the necessary precautionary measures in order to operate the installation safely.</li><li>• Starting up the installation in an area with a risk of explosion is prohibited.</li><li>• The installation has been so designed that production is safe under normal ambient conditions.</li><li>• The owner of the installation must ensure that the instructions in this manual are followed in practice.</li><li>• The safety features provided must not be removed.</li><li>• Correct operation and safety of the system can only be guaranteed where maintenance is carried out correctly and in good time, as prescribed.</li><li>• Where work is to be carried out on the installation it must be disconnected from the power supply, the power supply must be locked off and the system must be depressurised.</li><li>• There is a risk of trapping when operating driven moving parts. It is the operator's responsibility to ensure that the installation is only started up when no parts of his own or other people's bodies are in the vicinity of the trapping zone.</li></ul>
	<ul style="list-style-type: none"><li>• Only authorised persons appointed by the owner may carry out work on the electrical installation.</li><li>• Ensure by means of internal procedures and supervision that all applicable power supplies have been switched off.</li><li>• The installation must not be used during cleaning, inspection, repairs or maintenance, and must be disconnected from the electrical supply by means of the plug and/or the main switch.</li><li>• Welding work must not be carried out on the installation unless the cable connection to the electrical components has first been disconnected.</li><li>• The power supply to the control cabinet must not be used for the connection of machinery other than the hand tools provided for.</li></ul>



### 3.2. During normal use



- Check before commencing operations that no work is being carried out on the installation and that it is ready for use.
- Unauthorised persons must not enter the operational area of the installation. It is the operator's task to check this.
- Components of the hydraulic system may reach high temperatures. Contact with these components may cause injury.

### 3.3. Operating personnel



- Operating personnel must be aged 18 or above.
- Only authorised persons may carry out work with or on the installation.
- Only work for which proper training has been received must be carried out. This applies both to maintenance activities and normal use.
- The operating personnel must be familiar with all potential situations, so that rapid and effective action can be taken in an emergency.
- Where a member of operational staff observes defects or risks or is not in agreement with the safety measures, this must be reported to the owner or the manager.
- Safety footwear is mandatory.
- Suitable work clothing is mandatory.
- All employees must observe the safety instructions to avoid presenting a risk to themselves and others. Comply strictly with the operating instructions at all times.

## 4. Installation

	<p>EXPLANATION</p> <ul style="list-style-type: none"> <li>Consult the technical data and the circuit diagram provided for the correct specifications.</li> </ul>
---	--

### 4.1. Location

	<p>CAUTION</p> <ul style="list-style-type: none"> <li>The machine must be transported and installed upright.</li> <li>Place the machine on a level and stable non-slip substrate.</li> <li>Take account of the instructions in Section 3 when carrying out any activity. Failure to follow these may lead to serious injury.</li> </ul>
---	---

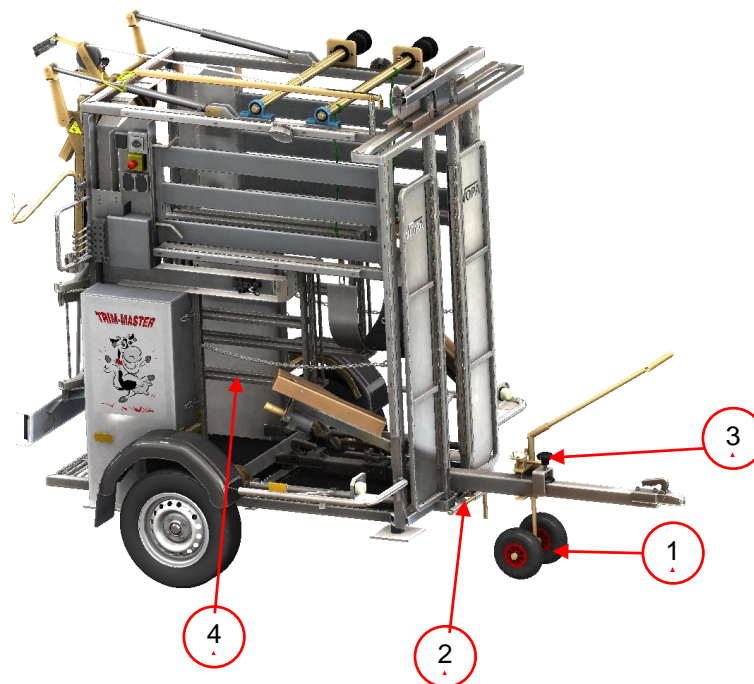



Figure 3 details of conversion from transport set-up to working set-up (SA0049)

No.	What to do	Action	Result
1.	Tip the nose wheel downwards.	<ul style="list-style-type: none"> <li>Ensure that the crush is resting on the nose wheel.(Figure 3 : 1)</li> </ul>	
2.	Connect the crush.	<ul style="list-style-type: none"> <li>See 4.2,5.2</li> </ul>	
3.	Open the front gate.	<ul style="list-style-type: none"> <li>Operate the valve to open the front gate.</li> </ul>	

4.	Remove the mudguards	<ul style="list-style-type: none"> <li>Loosen the locking elements and lift the mudguard out of the adapter.</li> </ul>	
5.	Tip the crush back.	<ul style="list-style-type: none"> <li>Tip the crush to the rear so that the drawbar is clear of the ground. With the rear gate raised the crush will remain in that position. Check that the folding gates are still secured with the front support feet ropes.</li> </ul>	
6.	Remove the locking pin from the drawbar.	<ul style="list-style-type: none"> <li>Rotate the locking pin upwards and remove it. (Figure 3 :2)</li> </ul>	
7.	Free the drawbar.	<ul style="list-style-type: none"> <li>Rotate the locking knob and unlock the clamp situated in the middle of the drawbar, then slide the nose wheel of the crush off until the drawbar comes free from the crush. (Figure 3 : 3)</li> </ul>	
8.	Tip the crush forwards.	<ul style="list-style-type: none"> <li>Lift the rear of the crush so that it tips forwards. The drawbar now rests on its nose wheel and the ball joint connection in the box.</li> <li>Disconnect the drawbar ball mounting.</li> </ul>	
9.	Tip the axle.	<ul style="list-style-type: none"> <li>Lift the axle cylinder locking mechanism.</li> <li>Operate the valve until the wheels are folded up.</li> </ul>	
10.	Remove the drawbar.	<ul style="list-style-type: none"> <li>Remove the drawbar from the crush and store it out of the way. The shaft will be held upright by the elastic cord attached to the ball mounting.</li> </ul>	
11.	Remove the lighting board.	<ul style="list-style-type: none"> <li>Remove the lighting board from the crush.</li> </ul>	
12.	Install the side gates.	<ul style="list-style-type: none"> <li>Withdraw the side gates from the crush and place them in the desired position. (Figure 3 : 4)</li> </ul>	

## 4.2. Connect the machine.

	<p style="text-align: center;">CAUTION</p> <ul style="list-style-type: none"><li>• Check that the voltage specified on the machine plate matches the mains supply.</li><li>• The machine must always be connected to an earthed socket to avoid the risk of fire or electric shocks (the earth connection is coded green/yellow).</li><li>• The electrical installation including the sockets must be connected in accordance with local regulations.</li><li>• The power cable must always be free and nothing must be placed on top of it.</li><li>• Replace the power cable immediately if it is damaged.</li></ul>
---	--

## 4.3. Preparing for transportation.

	<p style="text-align: center;">CAUTION</p> <ul style="list-style-type: none"><li>• Preparing for transportation is the reverse procedure to making ready for use (see 4.1).</li><li>• With crushes equipped with an axle and drawbar it is essential that all locking mechanisms are correctly installed.</li></ul>
--	---

## 5. Operation

	<p>CAUTION</p> <ul style="list-style-type: none"> <li>Take account of the instructions in Section 3 when carrying out any activity. Failure to follow these instructions may lead to serious injury.</li> </ul>
---	---

### 5.1. Starting up

No.	What to do	Action	Result
1.	Switch on the power.	<ul style="list-style-type: none"> <li>Insert the plug in the socket.</li> </ul>	
2.	Reset the emergency stop.	<ul style="list-style-type: none"> <li>Pull out the emergency stop buttons.</li> </ul>	The control unit is now ready for use.

### 5.2. Emergency stop.

	<p>CAUTION</p> <ul style="list-style-type: none"> <li>The emergency stop button must always be pressed in in the event of an emergency.</li> <li>All motions will cease following operation of the emergency stop button.</li> <li>In order to take the machine back into use after an emergency stop the emergency stop button must first be reset.</li> <li>Before resetting the emergency stop button it must be ensured that restarting the moving parts of the machine will not lead to a hazardous situation.</li> </ul>
---	--

- Reset the emergency stop**

No.	What to do	Action	Result
1.	Reset the emergency stop button.	<ul style="list-style-type: none"> <li>Reset the emergency stop button by pulling it out or rotating it (depending on the type installed) so that it returns to its original position.</li> </ul>	The machine is now ready for use.

### 5.3. Production

No.	What to do	Action	Result
1.	Check that the crush is ready for use.	<ul style="list-style-type: none"> <li>See Sections 5.1 and 5.2.</li> </ul>	
2.	Place the front gate ready.	<ul style="list-style-type: none"> <li>Open the front gate so that the head of the animal can pass through but not its withers. When the front gate is closed hydraulically it will stop at the correct position and the handle can be released. This means that the holding position is always the same.</li> </ul>	
3.	In order to	<ul style="list-style-type: none"> <li>Lead the cow into the crush until its head has passed through the front gate.</li> <li>Close the front gate. Where a sensor is installed (option) the front gate will close automatically when the cow is in position.</li> </ul>	
4.	Bring the rear gate into position.	<ul style="list-style-type: none"> <li>Lower the rear gate.</li> <li><b>In order to avoid the risk of damage to the front legs, ensure that the rear gate is NOT pressed up tightly against the animal.</b></li> </ul>	
5.	Raise the belly belt.	<ul style="list-style-type: none"> <li>Bring the belly belt up under the belly of the cow.</li> </ul>	
6.	Process a rear hoof.	<ul style="list-style-type: none"> <li>Place the belt around the rear leg and raise the leg.</li> <li>Process the rear hoof.</li> <li>Allow the leg to drop and release it.</li> </ul>	
7.	Process a front hoof.	<ul style="list-style-type: none"> <li>Attach the front leg with the hook as shown in Figure 4. Operate the winch hydraulically until the leg is tight up against the block.</li> <li>Process the front hoof.</li> <li>Release the rope.</li> </ul>	See 5.4
8.	Lower the belly belt.	<ul style="list-style-type: none"> <li>Reverse the winch until the belly belt is on the ground.</li> </ul>	
9.	Release the crush.	<ul style="list-style-type: none"> <li><b>Check that all ropes and belts have been freed.</b></li> <li>Open the front gate.</li> <li>Lead the cow out of the crush.</li> </ul>	
10.	Place the rear gate in its raised position.	<ul style="list-style-type: none"> <li>Raise the rear gate.</li> </ul>	

#### 5.4. Hook up the front leg.



	<p style="text-align: center;">CAUTION</p> <ul style="list-style-type: none"><li>• To avoid injury to the front leg the rope must be applied correctly. (see Figure 4)</li><li>• In order to avoid the risk of permanent injury, ensure that the front leg is not winched too tight against the block.</li></ul>
---	--



Figure 4: detail of hooking up front leg

## 6. Maintenance

	<p><b>CAUTION!</b></p> <ul style="list-style-type: none"> <li>• Test the installation on completion of maintenance work or repairs to ensure that it can be used again safely.</li> <li>• Only trained technical personnel may carry out the maintenance activities described or repair work.</li> </ul>
---	--

### 6.1. Maintenance diagram

The diagram below shows the maintenance activities to be carried out.

Activity	note						See Section
		Daily	weekly	Every 100 animals	Annually	Every 2 years	
<b>General</b>							
Check on panic locks and hooks.	Renew where damage is visible.						
Check ropes and chains.	Renew where damage is visible.						
Check plugs, cables, controls and connections.	Alert a competent fitter where damage is visible.						
Check that the left and right front leg ropes are hanging at equal lengths.	Where these are driven by a single motor.						
<b>Cleaning</b>							
Clean the machine.							6.2
<b>Lubrication</b>							
Grease nipples on rear gate sliding section.	Bearing grease.						6.3
Other grease nipples.	Bearing grease.						
<b>Hydraulic installation</b>							
Check the oil level.	Checks must be carried out after 500 cows or where leakage occurs.						6.4
Replace oil and filter.							
<b>Axle and wheels</b>							
Check play in the wheels.							6.5
Check the tyre profile.	Have this inspected by a competent person.						
Check the tyre pressures.	Have this inspected by a competent person.						
<b>Drawbar</b>							



Play in ball mounting.	Replace where minor play is evident, or see markers on the side of the ball mounting.						
Ball and coupling in crush.	Check and clean						
Check the latch.	There must always be slight tension on the latch.						
Check the shaft bolts.	Every 10,000 km.						6.6

## 6.2. Clean the machine.

	<p>EXPLANATION</p> <ul style="list-style-type: none"> <li>• A high-pressure cleaner may be used for cleaning.</li> <li>• Avoid bearings, winches and motors when cleaning with a high-pressure cleaner. Spraying in these areas may result in a sharp reduction in service life.</li> <li>• Avoid all electrical components when cleaning with a high-pressure cleaner. Spraying in these areas may result in risk of electric shocks and /or a sharp reduction in service life.</li> </ul>
---	---

## 6.3. Lubrication of rear gate

	<p>EXPLANATION</p> <ul style="list-style-type: none"> <li>• The rear gate is slid out with the aid of gas springs fitted to the gate.</li> <li>• To prevent grease entering the gas springs and causing damage, the gate must only be lubricated when it is fully drawn back.</li> </ul>
---	--



1 2

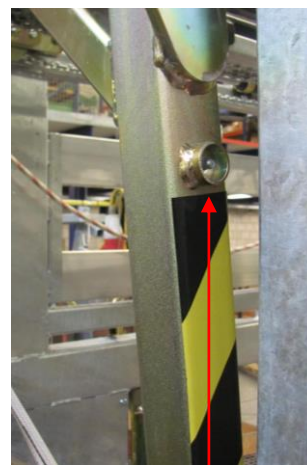

3

Figure 5: lubrication of rear gate

No.	What to do	Action	Result
1.	Retract the rear gate.	<ul style="list-style-type: none"> <li>• Attach the rear leg winch to the rear gate and tighten until the gate is fully retracted.</li> </ul>	
2.	Grease the nipples.	<ul style="list-style-type: none"> <li>• Lubricate the rear gate nipples using a grease gun.</li> </ul>	

## 6.4. Check oil level/replace oil.

	<p>EXPLANATION</p> <ul style="list-style-type: none"> <li>• Checking the oil level ensures that the necessary minimal amount of oil is present. The cylinders must be retracted for this purpose.</li> <li>• The general rule is that the oil and filter should be replaced every two years.</li> </ul>
---	---

### • Gauging the oil level

No.	What to do	Action	Result
1.	Retract the cylinders.	<ul style="list-style-type: none"> <li>• Put the cylinders in the installation in their retracted position by operating the valves.</li> </ul>	
2.	Check the oil level.	<ul style="list-style-type: none"> <li>• The oil level must now be between the minimum and maximum levels (see instructions on "changing the oil").</li> </ul>	

### • Changing the oil

No.	What to do	Action	Result
1.	Bring the oil to the tank.	<ul style="list-style-type: none"> <li>• See the instruction on "gauging the oil level".</li> </ul>	
2.	Empty the tank	<ul style="list-style-type: none"> <li>• Remove the plug from the tank and allow the oil to run out until it is empty.</li> </ul>	
3.	Fill the installation.	<ul style="list-style-type: none"> <li>• Fill the tank via the filler cap.</li> </ul>	
4.	Check the oil level.	<ul style="list-style-type: none"> <li>• The oil must be between the two lines on the filler cap dipstick.</li> </ul>	

- The following types of oil are suitable for use in the hydraulic installation:

Supplier	• Summer oil
• BP	• Energol HLP-HM 68
• Agip	• OSO 68
• Aral	• Vitam GF 68
• Beverol	• Inula 68
• Castrol	• Hyspin AWS 68
• Elf	• Elfolna 68
• Esso	• Nuto H 68
• Fuchs	• Renolin D 68
• Kroon Oil	• Perlus AF 68
• Mobil	• DTE 26
• Pennzoil	• AW Hydraulic Oil 68
• Q8	• Haydn 68
• Shell	• Tellus 68
• Sunoco	• Sunvis 800 WR 68
• Texaco	• Rando HD68
• Total	• Azolla ZS 68
• Unil	• HFO 68

**Figure 6: hydraulic fluids to be used**

### 6.5. Check play in the wheels.

	<p>EXPLANATION</p> <ul style="list-style-type: none"> <li>• Raise the wheels from the ground and feel if any play is present.</li> <li>• If play can be detected this must be corrected by a competent person, or otherwise the bearings and seals must be replaced.</li> </ul>
---	---

### 6.6. Check the shaft bolts.

	<p>EXPLANATION</p> <ul style="list-style-type: none"> <li>• After 10,000 km or once annually the shaft bolts must be tightened with a torque wrench in accordance with the figure below.</li> </ul>
---	---

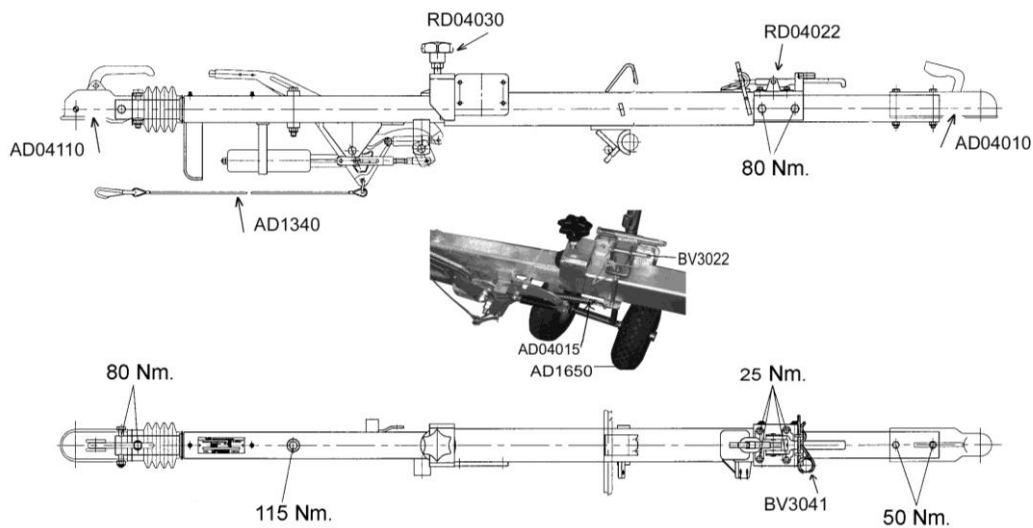



Figure 7: Details of shaft bolt torque settings

### 6.7. Parts

	<p>EXPLANATION</p> <ul style="list-style-type: none"> <li>• Consult the website at <a href="http://www.wopa.com">www.wopa.com</a> for information on the available options and the parts available to order.</li> </ul>
---	---

## 7. Disposal as waste

Oil and components must not be disposed of as domestic waste. When replacing components or oil or at the end of the machines service life, ensure that all materials are collected and destroyed or reused in a legal and environmentally friendly manner.





